

# FOT 1230



## INTRODUCTION

FOT-1230 is a clean, safe fire-fighting agent for use in total flooding automatic extinguishing systems. It is intended as a long-term replacement for Halon 1301 and, whilst maintaining the excellent fire suppression properties of Halon, has none of the environmental problems.

Storage and distribution requirements are similar to Halon and the majority of system components are identical. However, FOT-1230 is not a direct replacement for existing Halon 1301 installations due to the difference in agent quantity and discharge characteristics.

This systems may be activated mechanically or electrically. Mechanical manual actuation is via a manual actuator attached to the container valve. Electrical actuation is via a removable side mounted solenoid or a top mounted electrical actuator. Actuation can occur automatically via a signal from a detection and alarm control panel.

Users of this manual should find that sufficient information is provided to plan, design, purchase components, install, operate and maintain the system. However, in the event that part of the document is not understood, or if there is any concern as to the suitability of the protection, do not hesitate to contact one of our specialist engineers for the matter to be quickly resolved.



## Health and Safety

A properly designed and installed extinguishing system should not present any significant health or safety problems, however, there are basic precautions to be taken to avoid accidents, and aspects of the system operation that should be understood. End-users often require reassurance regarding the safety of personnel, and this can only be given if a thorough understanding of the properties of the agent and its effects in different situations are known. Best practice should be observed.

FOT-1230 extinguishes primarily through heat absorption, and does not sufficiently deplete oxygen levels.



## Properties

Chemical Name	FK-5-1-12
Empirical Formula	$\text{CF}^3\text{CF}^2\text{C}(\text{O})\text{CF}(\text{CF}^3)^2$
Molecular Weight	316.04
Boiling Point	49°C
Freezing Point	-108°C
Viscosity Liquid (25°C)	0.524CP
Vapor Pressure (25°C)	40.4KPa
Extinguishing Concentration (Cup)	3.5%
NOAEL (V/V)	10%
LOAEL (V/V)	>10%
LC50 (V/V)	>10%
Ozone Depleting Potential	0
GWP	1



System Components

This section describes the individual components that comprise a complete system. Some items are optional depending on the application, and are indicated as such.

FOT-1230 Container

The container assembly consists of a container fitted with a valve and internal syphon tube, factory filled with FOT-1230, and super-pressurized with dry nitrogen to 25 bar @ 21 C (360 psi @ 70 F).

Containers sharing the same manifold shall be equal in size and fill density. Containers are finished in red and are available in various sizes.

A nameplate is fixed to the container displaying the agent weight, tare weight, gross weight, fill density, charge date and fill location.

FOT-1230 Container



Technical Information

The 8, 16, 32, 52, 106, 147, 180 and 343 litre containers are manufactured in accordance with EN324 or EN13322, and DOT 4BW406.

Material: Carbon Steel  
**EN324**

Hydraulic test pressure: 69.0 bar (1000 psi)

Working Pressure: 34.5 bar (500 psi)

**EN13322**

Hydraulic test pressure: 62.1 bar (900 psi)

Working Pressure: 31.0 bar (450 psi)

Paint Specification: Red epoxy polyester or red polyester powder coated

Material: Carbon Steel

Hydraulic test pressure: 40.0 bar (580 psi)

Working Pressure: 34.5 bar (500 psi)

Paint Specification: Red epoxy polyester or red polyester powder coated

AGENT CONTAINER AND VALVE ASSEMBLY:



Part No. (Nominal Volume)	Minimum and Maximum Fills kg	Valve Size mm (in)	Height from floor to outlet (nominal)		Diameter mm (in)	Nominal Tare Weight kg
			mm	(in)		
FOT-1011-39-8L -C (8 litre)	4.0 to 9.6	25 (1")	304	(12")	254 (10")	14.8
FOT-1011-12-16L -C (16 litre)	8.0 to 19.2	25 (1")	502	(19.8")	254 (10")	18.4
FOT-1011-13-32L -C (32 litre)	16.0 to 38.4	25 (1")	833	(32.8")	254 (10")	26.1
FOT-1011-14-52L -C (52 litre)	26.0 to 62.4	50 (2")	596	(23.5")	406 (16")	49.1
FOT-1011-15-106L -C (106 litre)	53.0 to 127.2	50 (2")	1021	(40.2")	406 (16")	71.8
FOT-1011-17-147L -C (147 litre)	73.5 to 176.4	50 (2")	1354	(53.3")	406 (16")	89.9
FOT-1011-18-180L -C (180 litre)	90.0 to 208	50 (2")	1634	(64.3")	406 (16")	105.8
FOT-1011-19-343L -C (343 litre)	172.0 to 386	75 (3")	2050	(80.7")	517 (20")	207.0



Container Label

The container label details the weight of FOT-1230 contained, empty weight, fill density and charge date. Once the label is applied to the container surface, and to avoid possible tampering it cannot be removed intact.

Container Label

<p>PART NUMBER</p> <p>AGENT WEIGHT</p> <p>TARE WEIGHT</p> <p>GROSS WEIGHT</p> <p>FILL DENSITY</p> <p>CHARGE DATE</p> <p>FILL LOCATION</p>		<p>KG</p> <p>KG</p> <p>KG</p> <p>KG/L</p>	 <p><b>FOT 1230</b></p> <p>CONTAIN FOT-1230 (FK-5-1-12) SURPPRESSURIZED TO 25 BAR AT 21°C</p>	 <p>Cleans Extinguishing Agent</p> <p>THIS CONTAINER IS FILLED WITH FK-5-1-12 (DODECAFLUORO-2-METHYLPENTAN-3-ONE) AND IS SUPERPRSSURIZED TO 25 BAR (362.5 PSI) AT 21°C (70°) WITH DRY NITOGEN</p> <p>ENVIRONMENTALLY FRIENDLY FIRE SUPPRESSION AGENT</p>
<p><b>ABC</b></p> <p>CARBONACEOUS MATERIALS, FLAMMABLE LIQUID AND GASES, AND FIRE IN ELECTRICAL EQUIPMENT</p>	<p><b>WARNING:</b> The discharge of clean agent systems to extinguish a fire can result in a potential hazard to personnel from the natural form of clean agent or from the products of combustion that result from exposure of the agent to the fire or hot surfaces. Unnecessarily exposure of personal either to the natural agent or to the products decomposition shall be avoided.</p>		<p><b>CAUTION:</b> Uncontrolled valve operation could result in severe injury or death to operators or bystanders, ensure safety outlet cap is in place if container is disconnected from pipe work containers should not be positioned in direct sunlight</p>	
<p><b>MAINTENANCE:</b></p> <p>Carefully follow the instruction below and those contained in the design manual.</p> <p>Inspect the system frequently and check the pressure gauge weekly.</p> <p>Check agent quantity and pressure every six months.</p> <p>1.If the pressure gauge indicates a loss of pressure (when adjusted for temperature) of more than 10% then recharge with oxygen free nitrogen to 25 bar at 21°C, adjusted for temperature (Refer to table in a design manual).</p> <p>2. If the loss in weight is more than 5% of the agent weight indicated on this, the unit must be recharged</p>		<p><b>INSPECTION OF SUPPRESSION SYSTEM</b></p> <p><b>MONTHLY INSPECTION</b></p> <p>Examine piping and nozzles to make certain they are unobstructed.</p> <p>Check container pressure if loss exceeds 10% (when adjusted for temperature), refill or replace container.</p> <p><b>6-MONTH INSPECTION</b></p> <p>Check agent quantity for pressure refill or replace in loss in agent quantity of more than 5% or a loss in pressure (adjusted for temperature) of more than 10% is determined.</p> <p>This system is made up of units tested within limitations contained in the detailed instruction manual. This system should be periodically inspected by trained personnel. The system designer must be consulted whenever changes are planned for the system or area of protection.</p>		<p>THE DATE OF MANUFACTURE IS ON THE CONTAINER</p> <p>SUITABLE FOR USE IN AMBIENT TEMPERATURE OF 0°C TO 54°C (32°F TO + 130°C)</p> <p>16, 32, AND 52 LITRE CONTAINERS MUST BE TRANSPORTED AND STORED IN THE VERTICAL POSITION</p> <p>FACTORY TESTED</p>
<p style="text-align: center;"><b>RECYCLING PROJECTS THE ENVIRONMENT</b></p> <p>Do not dispose. Discharge charge only in case of fire. If container contents must be removed for service, maintenance or dismantling of the clean agent system, prior to removal contact your local installer or manufacturer for instructions on handling the equipment and on reclaiming or recycling clean agent.</p>			<p style="text-align: center;">www.fotfirecontrol.co.uk sales@fortfirecontrol.co.uk Unit 3 Merchant, Evegate Business Park, Smeeth Ashford Kent, Tn24 9RS U.K</p>	
<p style="text-align: center;"><b>FOT 1230 SHOULD ONLY BE DISCHARGED IN RESPONSE TO A CONFIRMED FIRE</b></p>		<p style="text-align: center;"><b>DO NOT COVER, REMOVE, OR DEFACE THIS LABEL</b></p>		



### Valve Assembly

The container valve is the result of extensive research and development and incorporates many unique safety features. The valve assembly is factory-fitted to the container and is supplied pre-assembled with a low pressure switch (to be ordered separately), pressure gauge and burst disc.

Valve Assembly:



25 mm (1") Valve Assembly

50 mm (2") Valve Assembly

### Technical Information

<b>25 mm (1") Valve</b>	
Body Material:	Brass CZ 121
Outlet Anti-Recoil Cap Material:	CZ122
Max. Working Pressure:	34 bar (493 psi)
Outlet:	25mm (1" BSPP)
Low Pressure Switch Port:	1/8" NPT
Gauge Port:	1/8" NPT
Pilot Pressure Port:	1/4" BSPP
Solenoid Adaptor Port:	1/8" NPT
Overall Size:	130mm (L) x 62mm (Dia) (5.12" (L) x 2.44" (Dia))
Weight:	2.96 kg (6.526 lbs)
Equivalent Length:	6.096 m (20 ft)

<b>50 mm (2") Valve</b>	
Body Material:	Brass CZ 121
Outlet Anti-Recoil Cap Material:	CZ122
Max. Working Pressure:	34 bar (493 psi)
Outlet:	50mm (2" BSPP)
Low Pressure Switch Port:	1/8" NPT
Gauge Port:	1/8" NPT
Pilot Pressure Port:	1/4" BSPP
Solenoid Adaptor Port:	1/8" NPT
Overall Size:	173mm (L) x 100mm (Dia) (6.12" (L) x 3.94" (Dia))
Weight:	9.18 kg (20.238 lbs)
Equivalent Length:	10.668 m (35 ft)



**DOOR NOTICE**

A door notice is required at each entrance of the hazard area to advise personnel that they are entering a protected area.

**MANUAL RELEASE NOTICE**

A notice should be located at each manual release position.

Door Notice

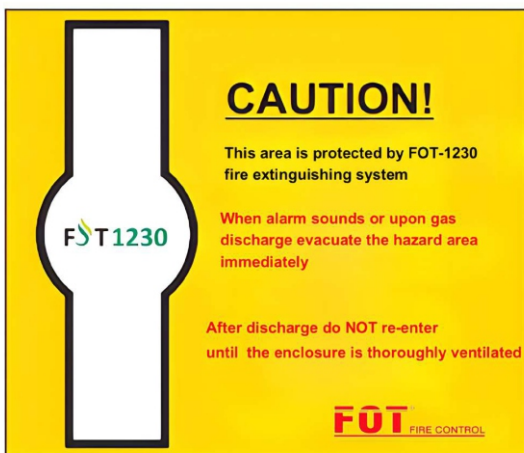

For areas protected by concentrations greater than NOAEL (unoccupied spaces only).

Manual Release Sign

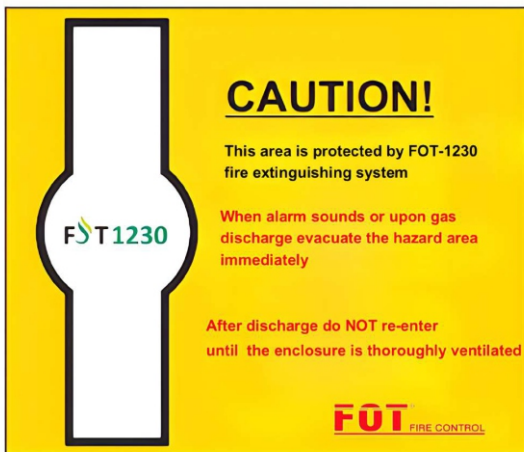



Typical Manifold System



## System Design

There are two main elements of system design. The first is the risk assessment; determining the type of protection required, considerations such as ventilation, openings and restrictions; equipment location. etc. The second is calculating the quantity of FOT-1230 required, including floor and/or ceiling voids, positioning of nozzles, electrical requirements, etc.

## Hazard Analysis

The first, and one of the most important, exercises in planning a FOT extinguishing system is the hazard survey. The information derived from the survey should include risk assessment, environmental conditions, personnel considerations, system operation both in normal conditions and after a discharge, access and construction limitations, dimensions, volumes, and any special requirements.

FOT systems are suitable for use in normal commercial and industrial environments. The minimum design concentration for Class A & C fires is 4.2% but differs for Class B fires. To determine other recommended design concentrations for Class B flammable liquids. All design concentration calculations are based on extinguishing concentrations plus 20% safety factor for Class A & C and 30% safety factor for Class B.

All agent quantities are calculated at minimum design temperature to determine agent quantity. Maximum achieved concentration should be calculated at the maximum anticipated enclosure temperature, and compared to NOAEL / LOAEL values.

Caution. FOT-1230 is not effective on the following: -

- Class A Deep seated fires.
- Class D Combustible metals.
- Chemicals capable of auto-thermal recombination.
- Chemicals capable of rapid oxidation.
- Enclosures with hot surfaces (>400 °C) (752°F)

## Hazard Structure

The protected enclosure shall be bounded by rigid elements of building construction. The ceiling should be not less than 0.3 m (1.ft) above the hazard.

During agent discharge, the hazard enclosure will experience a pressure change. Consideration should be given to mitigating these pressure changes.

## Hazard Volume

In total flooding applications the risk area must comprise an enclosed space with no significant openings so that the design concentration can be achieved and maintained. Generally, the calculation is based on an empty area; the subsequent furniture and fittings having little effect on the actual concentration. Similarly, large equipment cabinets and control panels should not be considered in the calculation as it is assumed that the internal area is required to be filled with agent.

Each enclosed space is considered as a risk area and requires at least one nozzle. A floor void, ceiling void, cable duct, etc., is treated as a separate adjacent area and requires simultaneous discharge to occur.

Ceiling obstructions such as beams that are less than 300 mm (12") below the slab need not be considered. Obstructions greater than 300 mm (12") can affect the distribution of agent and may require additional nozzles. Consult the technical support centre if in doubt.

To determine the volume refer to the site drawings, ensuring that the scale is accurate and that heights are denoted, or make a sketch of the area adding dimensions and any relevant details. Calculate the volume of each area.



## Ventilation

If the hazard enclosure has no means of adequate venting after discharge, consideration should be given to installing a normally closed means of ventilation with extraction arrangements which will discharge directly to atmosphere.

Air conditioning and/or forced ventilation can affect the system performance and the quantity of agent required.

(i) Self-contained air conditioning unit A self-contained unit conditions the air within the enclosure and does not rely on a fresh air supply, or draw air from other parts of the building.

If the hazard has a self-contained unit and it is located within the area without an outside air supply, no additional agent is required. It is not necessary to shut down the unit prior to a discharge as the mixing effect is beneficial.

(ii) Central air conditioning unit

A central air conditioning unit relies on air from outside and is often linked by ducts to other parts of the building, therefore, prior to a discharge, the unit should be shut down and/or dampers operated to close the ducts. Sufficient time must be allowed for the plant to stop, or dampers to close, before discharge occurs.

Dampers should be installed in both supply and return air ducts, as close as possible to the area. The duct volume between the hazard and the damper must be added to the overall volume.

## Hazard Temperature

Determine as accurately as possible the anticipated minimum and maximum temperatures likely to be experienced within the protected area. Minimum agent quantity requirements are based on minimum temperature.

## Hazard Fuels

All fuels in the hazard must be identified and the corresponding agent concentration requirements assessed. The design concentration (percent by volume) required for the hazard will be the highest concentration required by any one of the fuels present in the hazard.

## Personnel Safety

Natural Agent: To avoid possible injury, avoid any exposure to FOT-1230 in volume concentrations greater than 10% unless using self-contained breathing apparatus.

Symptoms of overexposure to concentrations greater than 10.0% may include dizziness, impaired coordination, reduced mental acuity, cardiac effects or unconsciousness. In the event of overexposure, remove to fresh air immediately and summon medical assistance.

Frostbite: Direct skin contact with FOT-1230 in the immediate area of discharge may cause frostbite.

## Agent Quantities

Normally the agent quantity is the weight required to produce the desired concentration at the lowest temperature within the hazard enclosure.

## Agent Storage

FOT-1230 is stored as a liquid in appropriate containers to meet DOT4BW406 and EN 13322-1 requirements.

Nitrogen in the container maintains a super-pressurization of 25 bar at 21 °C (360 psi at 70 °F). The chosen location should provide protection from severe weather, mechanical, chemical, or other types of damage. Hydraulic calculations assume an agent temperature of 21 °C (70 °F). When the storage temperature varies by 5.5 °C (10 °F), there is a risk that the system will not supply the designed quantity of extinguishing agent.



## Agent Flow Characteristics

### Nitrogen Super-pressurization

Nitrogen is added to the FOT containers. This addition of nitrogen, known as superpressurization, will cause a portion of the nitrogen to mix with the FOT-1230, the remaining portion of the nitrogen will remain in the vapour space above the liquid providing the increased propulsion necessary to discharge the FOT-1230 from the container.

### Flow in Pipe

In a properly designed distribution piping network the flow of FOT-1230 will consist of a two phase mixture of liquid and vapour. The properties of this mixture will vary with its composition; therefore, when the mixture contacts the pipeline walls, the friction decreases the density of the mixture resulting in a non-linear pressure drop and an increase in flow velocity.

Another consequence of two-phase flow is the potential for separation of liquid and vapour. In a properly designed pipe network, the velocity of the mixture will be high enough to maintain highly turbulent flow. However, if the pipeline diameter is too large for the design flow rate, the two phases may separate, leading to alternate discharges of liquid and vapour (slugging) or layering of the two phases.

### Initial Vapour Discharge

At the instant the discharge valve is opened, rapid expansion of the agent will cool the piping network.

### Trailing Vapour Pressure

Discharge time is defined as the average liquid discharge time through all nozzles in the system. After the liquid portion of the discharge has been completed, there will be a short transition period followed by the delivery of the remaining FOT-1230 nitrogen mixture as a vapour. This is due to flashing of the trailing edge of the fluid as it moves from the tank to the nozzles. In some systems the transition period is relatively long; this can lead to confusion as to when the discharge is complete, possibly resulting in an inaccurate measurement of the discharge time.

### Nozzle Selection and Location

The number of nozzles required is based on the hazard size and configuration and the coverage provided by the nozzle. Nozzles are available in 7- port or 16-port versions to provide 180 or 360 degree discharge patterns respectively. When considering the optimum nozzle location, the following factors should be taken into account.

- Nozzle location is affected by the shape of the hazard area.
- The maximum discharge radius is 6.9 m (22.6 ft) for a 360 nozzle and 10.9 m (35.8 ft) for a 180 nozzle.
- The maximum coverage area for either nozzle is 96.0 m (1024 ft).
- Nozzle orifices must not be placed where they may discharge into nearby objects.
- Nozzles must be installed a maximum of 300 mm (12") below the ceiling.
- 4.3 m (14 ft) maximum protection height for 360 and 180 nozzle.
- 180 degree nozzles must be mounted adjacent to a wall and must be located to cover the entire area.
- 300 mm (12") minimum void height (i.e. Subfloors and false ceilings).
- Maximum distance 180 degree nozzles should be placed from a wall 300 mm (12"), the minimum 50 mm (2"). Measured from centre of the nozzle to the wall.
- Nozzles located both above and below the container outlet, Maximum distance between them 9.1m (30 ft).
- Nozzles located either above or below the container outlet, maximum distance between them 9.1m (30 ft).



### Nozzle Discharge Radius

The maximum discharge radius is 6.9 m (22.6ft) for a 360° nozzle and 10.9 m (35.8ft) for a 180° nozzle.

Figure 8 - Nozzle Discharge Radius

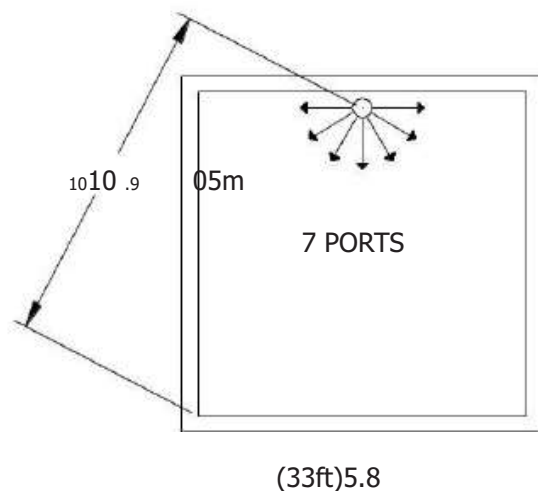
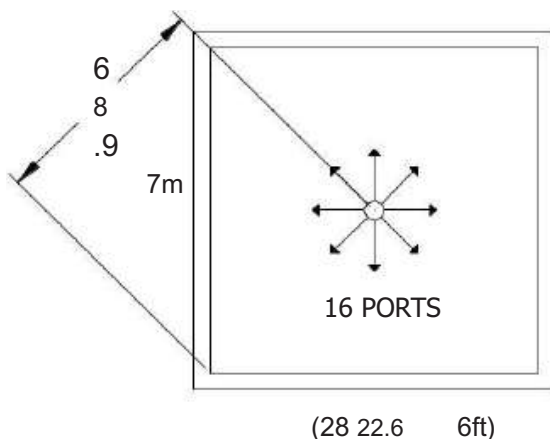

### System Design Procedure

The following procedure must be followed when designing FOT systems.

- Determine hazard material and required design concentration.
  - Identify individual enclosure volumes and deduct any impermeable volumes where appropriate.
  - Determine hazard altitude and correction factor.
  - Calculate quantity of FOT-1230 per enclosure, at minimum design temperature.
  - Determine container size and fill density.
  - Select nozzle type and location.
  - Design pipe network.
  - Calculate quantity of FOT-1230 per nozzle.
  - Check percentage agent split at tee's.
- 
- Identify all pipe lengths, rises, falls and nozzle reference numbers.

Note: The side tee splits shall be between 10-35%, bull tee splits will be between 30-70%. All Tee outlets must be in the same horizontal plane.

#### Example: Nozzle Selection

Room:	120.7 m <sup>3</sup> (4262.6 ft <sup>3</sup> )	1 x 7 port nozzle
Computer Room:	543.3 m <sup>3</sup> (19237.1 ft <sup>3</sup> )	4 x 16 port nozzles
Floor Void:	63.36 m <sup>3</sup> 2 x	



Example: Tee Split Designs

Side Tee Split limits.

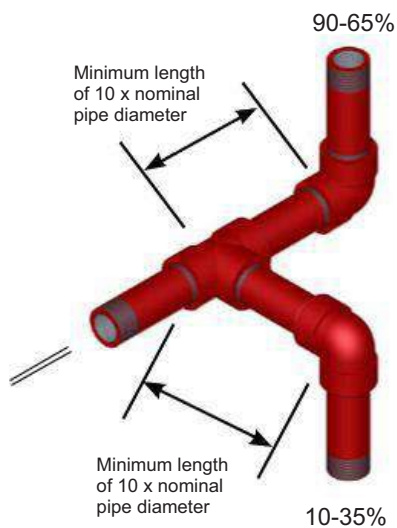

Bull Tee Split limits

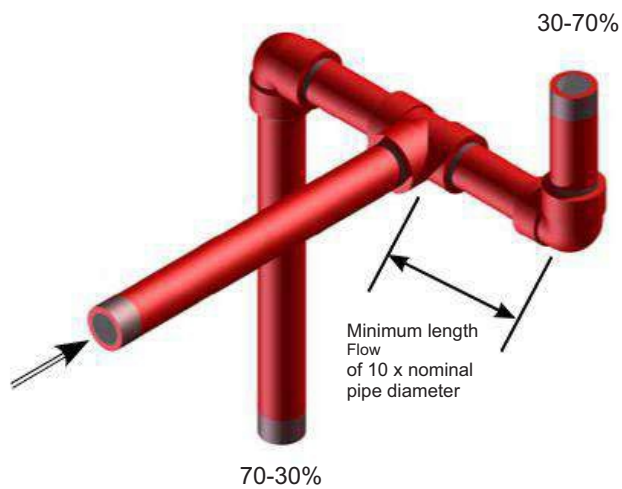

Side tee orientation "correct"

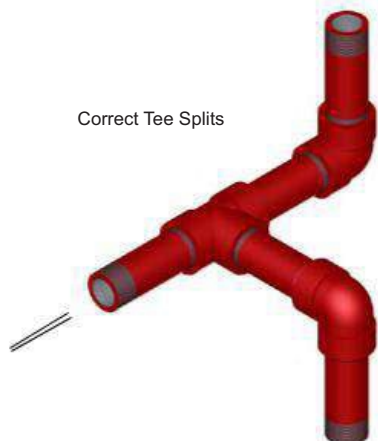

Side tee orientation "incorrect"



Bull tee orientation "correct"



Bull tee orientation "incorrect"



SYSTEM LIMITATIONS (Continued)

Piping Practices (Continued)

EXAMPLE: TEE SPLIT DESIGNS

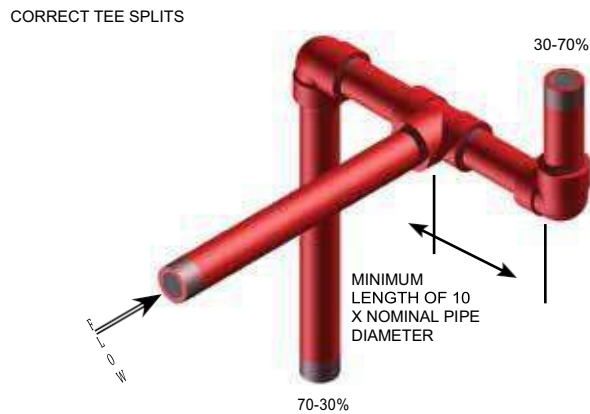
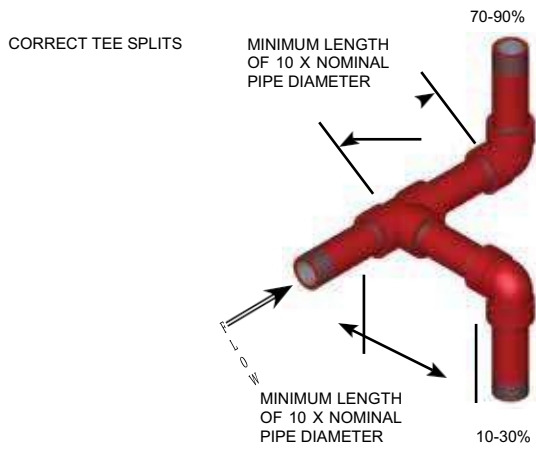

SIDE TEE SPLIT LIMITS

BULL TEE SPLIT LIMITS



SIDE TEE ORIENTATION "INCORRECT"

BULL TEE ORIENTATION "INCORRECT"

**General Information**

All installation shall be carried out by an approved contractor with the correct equipment and previous experience of gaseous extinguishing systems.

- Container Installation
- Piping and Nozzles
- Actuation Controls
- Ancillary Equipment
- Completion Procedures

Specific installation drawings must be prepared for the hazard area in accordance with system design as calculated by the FOT-1230 Hydraulic Flow Program. Installation drawings contain the following information;

- Enclosure Volumes.
- Agent Quantities.
- Scaled Pipe Network Plan.
- Pipe Network Isometric.
- Pipe Diameters, Pipe Length Drops & Rises.
- Nozzle Data.
- Container Data.
- Solenoid Actuator Technical Data.
- Low Pressure Switch Wiring Chart
- Fittings Data.

**Container Installation**

The container location is identified on the system drawings and should be protected from extremes of temperature, and be accessible for service and maintenance. The containers must be firmly secured to a wall or bulkhead, in a vertical orientation only.

Outlet Anti-Recoil and Actuation Caps

ACTUATION CAP

ANTI-RECOIL CAP



Anti-Recoil Caps  
 25 mm (1") 1" BSP Brass  
 50 mm (2") 2" BSP Brass  
 75 mm (3") 3" Flared Brass

Actuation Cap  
 25 mm (1") Plastic





## Single Container Installation

1. Fix the back channels of the mounting brackets to the wall at the appropriate heights, using suitable anchor type bolts (not supplied).
2. Position the container against the back channel with the valve outlet pointing left.
3. Insert the container straps at top and bottom and secure with the bolts provided.
4. Remove the anti-recoil cap from the valve outlet.
5. For 8 - 180 litre containers (25 mm (1") and 50 mm (2") valves): With the anti-recoil cap removed from the valve outlet, install a union coupling.
6. Install the initial pipe run and then disconnect the container and refit the anti-recoil cap to the valve outlet.
7. Re-connect the pipe to the container after the pipework system is complete and the discharge nozzles have been installed.

Figure 16 - Discharge Outlet Connections.

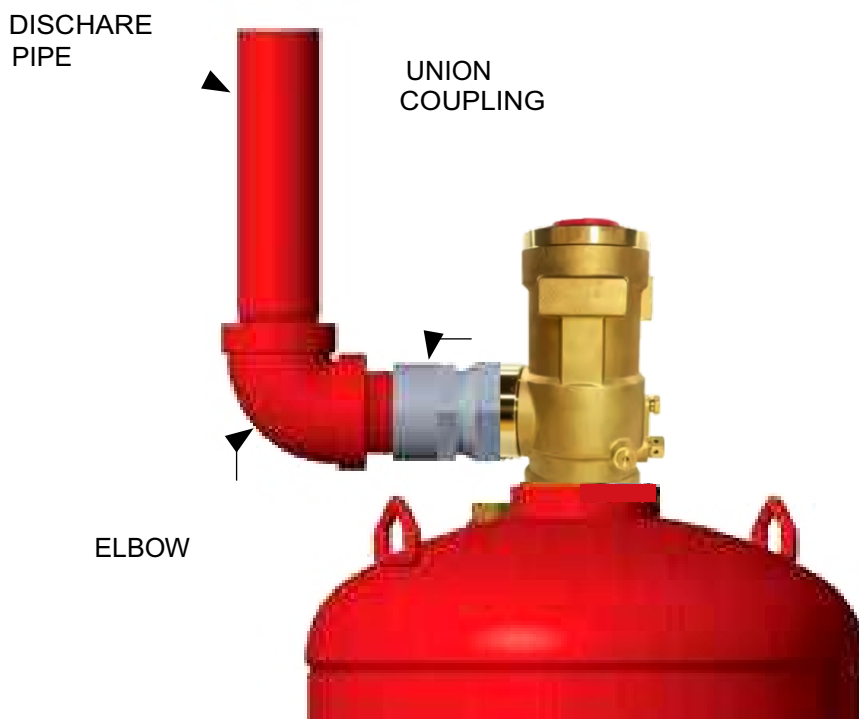

180 LITRE CONTAINERS 343 LITRE CONTAINER

## Bracket Fixing Heights

Container Size	No. of Unistrut Channels	Height From Floor to Bracket mm (in)
8 litre: 4.0 to 9.6 kg	1	130 (5")
16 litre: 8.0 to 19.2 kg	2	60, 330 (2.5", 13")
32 litre: 16.0 to 38.4 kg	2	160, 595 (6.25", 23.5")
52 litre: 26.0 to 62.4 kg	2	110, 343 (4.25", 13.5")
106 litre: 53.0 to 127.2 kg	2	300, 750 (11.75", 29.5")
147 litre: 73.5 to 176.4 kg	2	300, 1000 (11.75", 39.25")
180 litre: 90.0 to 180.0 kg	2	300, 1200 (11.75", 47.25")



## Multiple Container Installation

Containers are manifolded together for three main reasons;

- To reduce the amount of piping required by connection to one feeder pipe.
- For systems that require main and reserve.
- Combining the correct containers to obtain the required quantity of agent within a specific hazard area.

A typical 80 mm (3"), three port manifold assembly consists of the manifold, three check valves and an end cap. Each check valve is screwed to the manifold (25 mm (1") and 50 mm (2") valves only).

- 1 Fix the back channels of the mounting brackets to the wall at the appropriate heights, using suitable anchor type bolts (not supplied).
- 2 Position the containers against the back channels with the valve outlets pointing left at the required spacing for the manifold ports.
- 3 Insert the container straps at top and bottom and secure with the bolts provided.

## Manifold Bracket Installation

1. Fix the two back vertical channels to the wall at the appropriate height using suitable anchor type bolts.
2. Locate and secure the cantilever brackets to each channel using M10 x 40mm Hex Head screw and uninit long spring 10 mm.
3. Locate manifold brackets in cantilever channel and unirax end caps.
4. For 25 mm (1") and 50 mm (2") Valves: Remove anti-recoil cap and attach discharge hose between valve and manifold. Adjust cantilever height as required and secure in position.
5. For safety remove discharge hose and replace safety caps, while pipework is installed.
6. For 80mm (3") valve: To install hose/check valve assembly between the valve discharge outlet and the pipe manifold, complete the following steps:
  - a. Install the check valve into the manifold inlet.
  - b. Align the valve outlet with the inlet of the discharge hose. Install the swivel nut on the discharge valve. Wrench tighten.
  - c. Thread the hose swivel nut onto the check valve until the swivel nut covers the paint on the check valve threads.

Secure the nut with the locking set screw (provided) to prevent the nut from loosening with vibration.



**Table 3: Manifold Bracket Fixing Heights**

Container Size (L)	Valve Size mm (in)	Manifold Size mm (in)	Nominal Height from Floor to top of cantilever mm (in)
8 (1")	25 65 (2.5")	750 (29.5")	4.0 to 9.6 kg (9 to 21 lb)
16 8.0 to 19.2 kg (18 to 42 lb)	25 (1")	65 (2.5")	949 (37.4")
32 16.0 to 38.4 kg (36 to 84 lb)	25 (1")	65 (2.5")	1289 (50.75")
52 26.0 to 62.4 kg (58 to 137 lb)	50 (2")	80 (3")	1133 (44.6")
106 53.0 to 127.2 kg (117 to 280 lb)	50 (2")	80 (3")	1601 (63.0")
106 53.0 to 127.2 kg (117 to 280 lb)	50 (2")	100 (4")	1061 (63")
147 73.5 to 176.4 kg (162 to 388 lb)	50 (2")	80 (3")	1931 (76")
147 73.5 to 176.4 kg (163 to 388 lb)	50 (2")	100 (4")	1931 (76")
147 73.5 to 176.4 kg (163 to 388 lb)	50 (2")	150 (6")	1931 (67")
180 90.0 to 208.0 kg (199 to 459 lb)	50 (2")	100 (4")	2210 (87")
180 90.0 to 208.0 kg (199 to 459 lb)	50 (2")	150 (6")	2210 (87")

Manifold Assembly

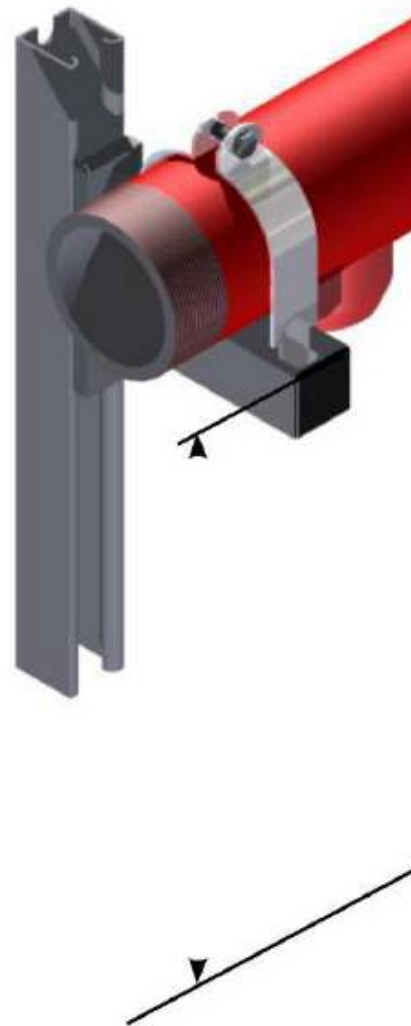

## Pipe Installation

In general, the installation should commence at the union elbow / manifold assembly and progress along to the discharge nozzles. Install the Pipework to the installation drawings provided, ensuring that the following is adhered to:

- The piping material must conform to the requirements of NFPA 2001 4.2
- The pipe must be reamed, blown clear and swabbed with an appropriate solvent to remove mill varnish and cutting oil before assembly as required by NFPA 2001 4.2.
- PTFE (Teflon) tape is the only acceptable pipe sealant and must be applied to the male threads.

## Pipe Hangers

Pipe hangers must be spaced according to the size of pipe.

- Hangers must be placed within 300 mm (12") of the discharge nozzle.
- Hangers must be placed between elbows that are more than 600 mm (24") apart.
- Hangers must be fixed to a structure capable of supporting the Pipework.

## Hanger Spacing

Pipe Size mm	Maximum Spacing m
15 (1/2")	1.5 (5 ft)
20 (3/4")	1.8 (6 ft)
25 (1")	2.1 (7 ft)
32 (1 1/4")	2.4 (8 ft)
40 (1 1/2")	2.7 (9 ft)
50 (2")	3.4 (11 ft)
65 (2 1/2")	3.5 (11.5 ft)
80 (3")	3.7 (12 ft)
100 (4")	4.3 (14 ft)
150 (6")	5.2 (17 ft)



Nozzle Fixing



### Nozzles

All nozzles require the installation of a dirt trap comprising 1 side tee, 2 nipples, and 1 pipe cap. Fit the nozzle to the nipple on the dirt trap and check the nozzle orifice to ensure proper orientation. Dirt trap lengths should be no more than 10 times nominal pipe diameter.

A false ceiling comprising loose tiles must have the tiles retained within a 2 m (6.5 ft) radius of the nozzle, to prevent movement during system discharge. Nozzles should be installed a maximum of 300 mm (12") below the ceiling.

Dirt Trap

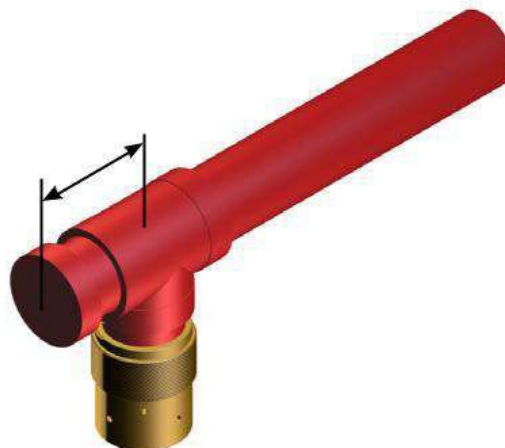

Elbow Support



### Earthing and Electrical Clearance

Systems within electrical substations or switch rooms shall be efficiently earthed to prevent the metalwork becoming electrically charged. Adequate earthing of systems will minimize the risk of electrostatic discharge. Where exposed electrical conductors are present, between the electrical conductors and all parts of the system that may be approached during maintenance



### Actuation Installation

The method of actuation depends on the system configuration and any specific contract requirements and can be broken down as follows:

- Single Container Actuation
- Multiple Container Actuation

### Single Container Actuation

#### Removable Electrical Actuator

The removable electrical actuator is fitted to the top of the valve assembly as follows:

- Check the actuator mechanism to ensure that it is in the non-fired position by fully screwing in the reset tool, i.e. pin retracted
- Remove the actuator cap from the top of the valve assembly.
- Carefully screw the actuator to the valve assembly.

**Note: The actuator must be hand tight only.**

If no other actuators are to be installed ensure that the protective cap on the actuator is retained in position.

Actuator Non-Fire Position



Electrical Actuator Location

## SECTION 4 - INSTALLATION

## EQUIPMENT: FOT-1230 (UL/FM)

### Manual Actuator

The manual actuator can be fitted to the top of the electrical actuator or directly onto the valve, after first removing the protective cap.

**Note.** The actuator must be hand-tight only.

### Multiple Container Actuation

Where several containers comprise one system and are discharged simultaneously, one container is designated as the 'master' container, and the others are 'slave' containers. The master container can be actuated electrically or manually.

The slave containers are actuated pneumatically by the action of the master container discharging.

### Pneumatic Actuator

Check that the actuating plungers are in the raised position. Remove the actuation cap from the top of the valve assembly and carefully screw the pneumatic actuator to the valve on each slave container.

**Note.** The actuator must be hand-tight only.

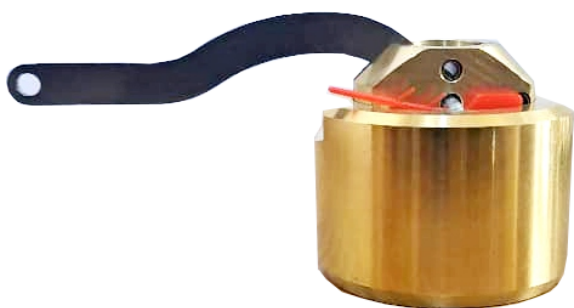

MANUAL ACTUATOR NON-FIRED POSITION



PNEUMATIC ACTUATOR NON-FIRED POSITION



MANUAL ACTUATOR INSTALLED



PNEUMATIC ACTUATOR INSTALLED



Multiple Container Actuation:



## Ancillary Equipment

### Discharge Pressure Switch

#### Single Container Systems

On single container installations the pressure switch should be located close to the valve assembly and connected with a pilot hose from the pressure port outlet on the valve to the connector on the pressure switch.

#### Discharge Pressure Switch Installation (Single Container System)



#### Multiple Container Systems

On multi-container installations the pressure switch should be located close to the last slave container and connected by pilot hose to the tee connector on the pneumatic actuator.

#### Discharge Pressure Switch Installation (Multiple Container System)



## Discharge Pressure Switch (Continued)

To wire the discharge pressure switch to the control panel, unscrew and remove the switch cover plate. Connect to the appropriate terminals on the microswitch or if supplied with wires, to the coloured wires which are labelled as follows:-

Common (C) (violet)

Normally Open (NO) (blue)

Normally Closed (NC) (black)

## Low Pressure Switch

All container valves are 'Factory fitted' with low pressure warning switches. Voltage input can be applied to either terminal.

Low Pressure Switch to Control Panel diagram.

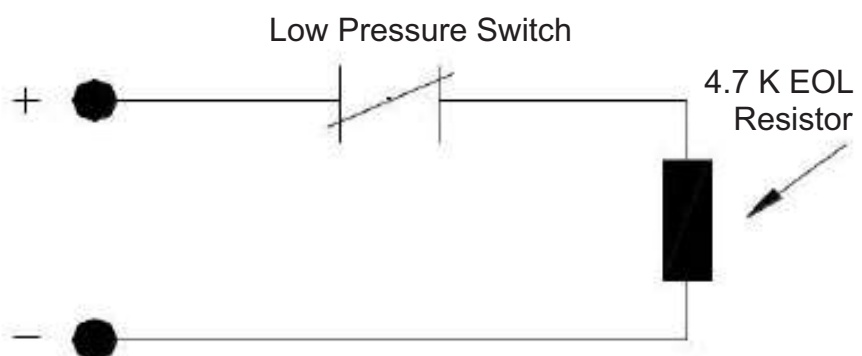
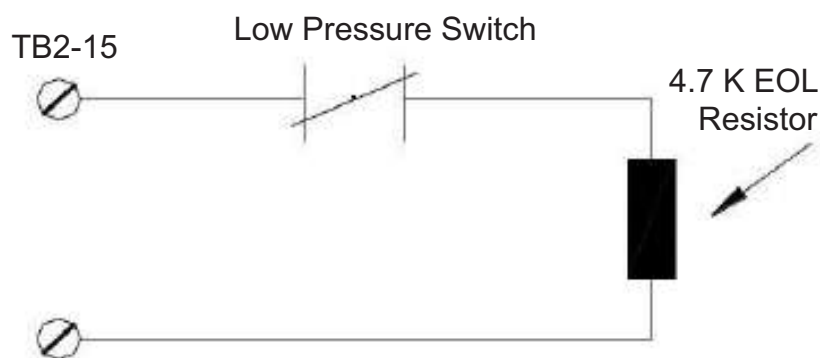

## Pre-checks and Visual Inspection

### General

When the installation is complete, and before making the final connections, the following checks should be made:

### Mechanical Checks

Inspect protected area closely for conformance to original risk specifications and for enclosable openings or sources of agent loss which may have been overlooked in the original specification.

- Building work should be thoroughly checked to ensure that enclosures have been properly constructed and that voids in floors and above suspended ceilings have been sealed.
- All back channels should be secured firmly to the wall or bulk head.
- Containers should be securely held within brackets.
- Piping should be securely fixed within hangers.
- All pipe connections must be tight.
- Nozzles to be the proper type, correctly placed, and properly orientated.
- Check model and weight markings on container nameplates to verify that correct containers and charges have been installed as required.
- Verify that all warning and instruction plates are mounted where required.

### Electrical Checks

The electrical systems may include interfaces with many other systems for alarm, indication, actuation, shutdown, etc. For complex electrical systems the scope and operating requirements will be described in other documents. Electrical checks are given below for a basic system using electrical actuation of the container valve;

- Remove top mounted electrical actuator or side mounted solenoid (which is connected via the solenoid adaptor) from valve. Check that solenoid is activated when system is triggered. If the solenoid adaptor is not present, remove electrical connections from side mounted solenoid and check wiring voltage is correct for actuation when system is triggered.

During detection system actuation verify the following functions operate;

- All apertures in hazard enclosure are closed by dampers or other suitable methods.
- Electrical equipment in the protected area is tripped and isolated.

### Pneumatic Checks

The slave actuators on manifolded systems are fired by agent discharge. Pneumatic checks are detailed below;

- Remove all pneumatic actuators from container valves.
- Disconnect pilot hose from the master container valve adaptor.
- Provide 4 bar (58 psi) pressure to the master container valve pilot hose.
- Verify all pneumatic actuator pistons are in the fired position.
- Check for leaks. There must be less than 10% loss in pressure within 1 minute).
- Provide 34 bar (493 psi) pressure to the master container valve pilot hose.
- Verify all pneumatic actuator pistons are in the fired position.
- Check for leaks. There must be less than 10% loss in pressure within 1 minute).



## Introduction

### User's Programme of Inspection

The installer should provide the user with an inspection programme for the system and components. The programme shall include instructions on the action to be taken in respect of faults. The user's inspection programme is intended to detect faults at an early stage to allow rectification before the system may have to operate.

#### Weekly Check of Containers

Check storage container pressure gauges and ambient temperature, compare these pressures to the Temperature Correction Chart to determine temperature corrected pressure. If the container corrected pressure shows a loss of more than 10%, the containers should be removed for weighing.

All measurements and actions shall be recorded in the log book.

#### Weekly Check of System Components

Make a visual inspection of the system components, distribution piping and nozzles.

Check the immediate vicinity of all equipment to ensure that no accidental damage or tampering has occurred.

#### Weekly General Check

Inspect the hazard area, access routes, container storage area, floor voids and areas above suspended ceilings to ensure housekeeping is good and that no refuse has accumulated. Ensure that access to the system container assemblies and local remote controls is unobstructed.

#### Monthly Check of Notices

Inspect system and protected spaces to ensure that warning signs, safety precautions and operating instructions are posted and clearly visible.

#### Monthly Personnel Training Check

Check that all personnel who may have to operate the equipment or system are properly trained and are authorized to do so, and in particular that new employees have been instructed in its use.



**Mechanical Servicing Procedure**

- a. Remove valve actuator(s) from the container valve(s).
- b. For master/slave system complete the following steps to check the slave actuation system:-
  1. Disconnect pneumatic valve actuators from the slave container valves.
  2. Disconnect the pilot loop from the master container valve and install the appropriate plug.
  3. Introduce 4 bar (58 psi) pressure into the pilot actuation line to the pneumatic actuators.
  4. Check that the pistons in the pneumatic valve actuators have fully operated.
  5. Check for leaks. There must be less than 10% loss in pressure within 1 minute).
  6. Vent pressure in the pilot actuation line and re-set all of the actuators.
  7. Introduce 34 bar (493 psi) pressure into the pilot actuation line to the pneumatic actuators.
  8. Check that the pistons in the pneumatic valve actuators have fully operated.

Check for leaks. There must be less than 10% loss in pressure within 1 minute).

9. Vent pressure in the pilot actuation line and re-set all of the actuators.
- c. To check the electrical actuation system (for single container systems only electrical actuators are fitted):
  - i) Remove electrical actuators from valve assemblies.
  - ii) Activate the detection system in accordance with procedures provided with the system. When this test is performed, the release circuit of the detection system must operate the electric actuators causing the plungers to be firmly extended.
  - iii) Examine the auxiliary electrical device/alarm, door closers etc., have all operated correctly.
  - iv) Ensure actuator is reset before refitting, using the reset tool provided.
- d. For master/slave system, remove the appropriate port plug and reconnect the pilot actuation line to the slave port on the back of the master valve.
- e. Reset pressure switches after the test has been completed.

(1) An approved distributor is carrying out the maintenance on the detection system.

(2) If the servicing of the detection system is being carried out at the same time as the mechanical service by another nominated body.

Finally

Carry out a final visual inspection of the system and the protected area to ensure that all equipment has been reinstalled and reconnected properly. Ensure that any associated control/indication panel is displaying normal operation. Complete the site log book, recording work carried out and parts used. Inform the responsible person that the work is complete and that the system is back on-line.



# FOT 1230

## Material Safety Data Sheet (MSDS)



## Section 1 – Company and Chemical Identification

### FOT Fire Control

Unit 3 Merchant Evigate  
Business park, Smeeth Ashford,  
Kent TN24 9RS England.

Issue Date: 24/02/18  
www.fotfirecontrol.co.uk

Product Name: FOT Novec 1230 Fire Protection Fluid [FK-5-1-12]

## Section 2: Hazards Identification

### 2.1 Emergency Overview

Odor, Color, Grade: Clear colorless, low odor gas.

### 2.2 Potential Health Effects

(Acute Exposure):

Eye Contact

Contact with the eyes during product use is not expected to result in significant irritation.

Skin Contact: Contact with the skin during product use is not expected to result in significant irritation.

Inhalation: Prolonged or repeated exposure, above recommended guidelines, may be absorbed following inhalation and cause target organ effects.

Ingestion: No health effects are expected.

Chronic Exposure:

FOR HUMANS:

EU Classification: This product is not classified as dangerous according to Directive 1999/45/EC.

Limit Values for Exposure: 1,1,1,2,2,4,5,5,5-Nonafluoro-4-(trifluoromethyl)-3-pentanone.

TWA Limit: 150 ppm. Limit set by FOT Company.

AS PART OF GOOD INDUSTRIAL AND PERSONAL HYGIENE AND SAFETY PROCEDURE, avoid all unnecessary exposure to the chemical substance and ensure prompt removal from skin, eyes, and clothing. DO NOT eat, drink or smoke when using this product.

Prolonged or repeated exposure, above recommended guidelines, may cause liver effects. Signs / symptoms may include loss of appetite, weight loss, fatigue, weakness, abdominal tenderness and jaundice.

MEDICAL CONDITIONS GENERALLY AGGRAVATED BY EXPOSURE: None known.

FOR ENVIRONMENT: No harm to the environment is expected from an accidental release of this preparation.

See Section 12,

ECOLOGICAL INFORMATION.

## Section 3: Composition/Information on Ingredients

C.A.S.	Ingredient Name	OSHA PEL	ACGIH TLV	OSHA STEL	%
756-13-8	1,1,1,2,2,4,5,5,5-NONAFLUORO-4-(Trifluoromethyl)-3- Pentanone	N/A	N/A	N/A >	99.9
7727-37-9	Nitrogen, Compressed	None	Simple Asphyxiant	N/A	1



## Section 4: First Aid Measures

### 4.1 First Aid Procedures

The following first aid recommendations are based on an assumption that appropriate personal and industrial hygiene practices are followed.

**Eye Contact:** Flush eyes with large amounts of water. If signs / symptoms persist, get medical attention.

**Skin Contact:** Wash affected area with soap and water. If signs / symptoms develop, get medical attention.

**Inhalation:** If signs / symptoms develop, remove person to fresh air. If signs / symptoms persist, get medical attention.

**If Swallowed:** Do not induce vomiting. Give victim two glasses of water. Never give anything by mouth to an unconscious person.

If signs / symptoms develop, get medical attention.

## Section 5: Fire Fighting Measures

### 5.1 Flammable Properties

**Autoignition temperature:** *Not Applicable.* **Flash Point:** *Not Applicable.*

**Flammable Limits - LEL** [*Details: Nonflammable*]. **Flammable Limits - UEL** [*Details: Nonflammable*].

### 5.2 Extinguishing Media

Product is a fire-extinguishing agent.

### 5.3 PROTECTION OF FIRE FIGHTERS

**Special Fire Fighting Procedures:** Wear full protective equipment (Bunker Gear) and a self-contained breathing apparatus (SCBA).

**Unusual Fire and Explosion Hazards:** Not applicable.

**Note:** See STABILITY AND REACTIVITY (SECTION 10) for hazardous combustion and thermal decomposition information.

## Section 6: Accidental Release Measures

For personal protection: Prevent skin and eye contact, see Section 8 EXPOSURE CONTROLS / PERSONAL PROTECTION.

Clean up: Ventilate the area with fresh air. Contain spill. For larger spills, cover drains and build dikes to prevent entry into sewer systems or bodies of water. Working from around the edges of the spill inward, cover with bentonite, vermiculite, or commercially available inorganic absorbent material. Mix in sufficient absorbent until it appears dry.

Collect as much of the spilled material as possible. Clean up residue. Place in a metal container approved for transportation by appropriate authorities. Seal the container. Dispose of collected material as soon as possible.

See Section 13, DISPOSAL CONSIDERATIONS.

NO harm to the environment is expected from an accidental release of this preparation.

See Section 12, ECOLOGICAL INFORMATION.

**In the event of a release of this material, the user should determine if the release qualifies as reportable according to local, state, and federal regulations.**

## Section 7: Handling and Storage

### 7.1 Handling

Contents under pressure. Avoid breathing of vapors, mists or spray. Avoid eye contact with vapors, mists, or spray.

Handle,

transport and store carefully and securely to avoid accidental knocking over or other severe physical impacts. Do not expose to direct heat sources. See incompatibility information in Section 10, STABILITY AND REACTIVITY.

### 7.2 Storage

Keep container in well-ventilated area. Do not store in temperature above 130°F (54°C). See incompatibility information in Section

10, STABILITY AND REACTIVITY. There is minimal danger to the environment from a storage release. See Section 12, ECOLOGICAL INFORMATION.

### 7.3. Specific use

The intended or recommended use of this preparation is as a FIRE EXTINGUISHING AGENT / SYSTEM.

## Section 8: Exposure Controls / Personal Protection

### 8.1 Personal Protective Equipment (PPE)

**Proper handling should not incur exposure to agent. As a precaution for accidental discharge or leakage, the following should be followed:**

#### 8.1.1 Eye / Face Protection

Avoid eye contact.

The following eye protection(s) are recommended: Indirect Vented Goggles.

### 8.1.2 Skin Protection

Avoid prolonged or repeated skin contact.

Select and use gloves and / or protective clothing to prevent skin contact based on the results of an exposure assessment. Consult with your glove and / or protective clothing manufacturer for selection of appropriate compatible materials. Gloves made from the following material(s) are recommended: Butyl Rubber.

### 8.1.3 Respiratory Protection

Avoid breathing of vapors, mists or spray. Under normal use conditions, airborne exposures are not expected to be significant enough to require respiratory protection.

Select one of the following NIOSH approved respirators based on airborne concentration of contaminants and in accordance with OSHA regulations: Half face piece or full face air-purifying respirator with organic vapor cartridges.

### 8.1.4 Prevention of Swallowing

Do not eat, drink or smoke when using this product. Wash exposed areas thoroughly with soap and water.

### 8.1.5 Hand protection

Butyl Rubber gloves are recommended. Select and use gloves and / or protective clothing to prevent skin contact based on the results of an exposure assessment. Consult with your glove and / or protective clothing manufacturer for selection of appropriate compatible materials.

## 8.2 Exposure Limit Values

1,1,1,2,2,4,4,5,5,5-Nonafluoro-4-(trifluoromethyl)-3-pentanone

TWA Limit: 150 ppm. Limit set by FOT Company.

## 8.3 Environmental exposure controls

There is minimal danger to the environment from a storage release. See Section 12, ECOLOGICAL INFORMATION.

## Section 9: Physical And Chemical Properties

**Specific Physical Form:** Liquid and gas mixture **Odor, Color, Grade:** Clear colorless, low odor.

**General Physical Form:** Liquid and gas **Autoignition temperature:** *Not Applicable*

**Flash Point:** *Not Applicable* **Flammable Limits - LEL** [*Details: Nonflammable*]

**Flammable Limits - UEL** [*Details: Nonflammable*] **Boiling point:** 49°C (120.6°F)

**Vapor Density:** 11.6 [*Ref Std: AIR=1*] **Vapor Pressure:** 244 mmHg [*@ 20 °C*]

**Specific Gravity:** 1.6 [*Ref Std: WATER=1*] **pH:** *Not Applicable*

**Melting point** -108°C **Solubility in Water:** Nil

**Evaporation rate:** > 1 [*Ref Std: BUOAC=1*] **Volatile Organic Compounds:** *No Data Available*

**Percent volatile:** 100 % **VOC Less H2O & Exempt Solvents:** *No Data Available*

**Viscosity:** 0.6 centipoise [*@ 25°C*]

## Section 10: Stability and Reactivity

**Stability:** Stable under normal conditions of handling and use.

**Materials and Conditions to Avoid:** Strong bases; Amines; Alcohols: Avoid direct sunlight and ultraviolet light for extended periods.

Do not store above 130°F (54°C) taking into account effects of sunlight.

**Hazardous Polymerization:** Hazardous polymerization will not occur.

**Hazardous Decomposition or By-Products:**

Combustion or decomposition products include carbon monoxide, carbon dioxide, and hydrogen fluoride.

## Section 11: Toxicological Information

Toxicity Data: Inhalation LC50 (rat) >10 % v/v.

NOAEL for cardiac sensitization >10 % v/v.

## Section 12: Ecological Information

**12.1. Ecotoxicity:** Not determined.

**12.2. Mobility:** Product is highly insoluble in water and volatile.

**12.3. Persistence and degradability:** Photolytic half-life is 3 to 5 days. The persistent photolytic degradation product is trifluoroacetic acid.

**12.4. Bioaccumulative potential:** Not determined.

**12.5. Other adverse effects:** Ozone depletion potential: None.

Photochemical ozone creation potential: None.

Global warming potential: 1.

### Section 13: Disposal Considerations

**Waste Disposal Method:** Reclaim if feasible. For information on product return, contact FOT Fire Control.

Incinerate in an industrial or commercial facility in the presence of a combustible material. Combustion products will include HF. Facility must be capable of handling halogenated materials.

As a disposal alternative, dispose of waste product in a facility permitted to accept chemical waste.

**Since regulations vary, consult applicable local regulations or authorities before disposal.**

### Section 14: Transport Information

Hazard Class or Division: 2.2. Label: Non flammable gas.

Proper Shipping Name: Compressed Gas, N.O.S, (nitrogen and fluorinated ketone mixture)

ID Number: EN 1001

Packing Group: N/A

Packing Instructions: 200 For additional transport information, contact FOT Fire Control.

No harm to the environment is expected from this preparation. See Section 12, ECOLOGICAL INFORMATION.

### Section 15: Regulatory Information

EU Classification: This product is not classified as dangerous according to Directive 1999/45/EC.

Exposure Limit Values: 1,1,1,2,2,4,5,5-Nonafluoro-4-(trifluoromethyl)-3-pentanone.

TWA Limit: 150 ppm. Limit set by FOT Company.

EINECS Status: The component of this product has been notified to ELINCS (European List of Notified or New Chemical Substances). Certain restrictions apply. Contact your distributor for additional information.

EPA TSCA Status: All components are included in TSCA inventories or are exempt from listing.

Environmental restrictions: None are known.

Restrictions on Marketing and Use: None are known.

Refer to any other national measures that may be relevant.

### Section 16: Other Information

#### WORKPLACE HAZARDOUS MATERIAL IDENTIFICATION SYSTEM RATINGS:

This product is rated: **Not Hazardous.**

#### HAZARDOUS MATERIAL IDENTIFICATION SYSTEM (HMIS) CODES:

HEALTH: 1 (slight hazard); FLAMMABILITY: 0 (will not burn); REACTIVITY: 0 (normally stable); PPE: See Section 8

### Section 17: Disclaimer of Expressed and Implied Warranties

FOT Fire Control has taken reasonable care in preparing this document, however, since the use of this information and the conditions of use of the product are not within the control of FOT Fire Control, it is the user's obligation to determine the conditions of safe use of this product. The information in this document is offered with no warranties or representations as to accuracy or completeness and it is the responsibility of each individual to determine the suitability of the information for their particular purpose(s)